

Ziegler

Redefine Innovative Metering

Technical Datasheet

ZAM LC60

DIGITAL POWER MONITORING METER – LOAD ANALYSER

ZAM LC60

DIGITAL POWER MONITORING METER – LOAD ANALYSER

ZAM LC60 Power Monitoring meter which can measure important AC electrical parameters in 1 ϕ and 3 ϕ systems. It measures all electrical parameters including Individual harmonics, %THD, Demand, RPM, Neutral current, Run-hours, On-hours and No. of interruptions.

Product Features

- On-site fully programmable
- THD and Individual Harmonic measurement up to 31st harmonics
- Percentage load bar graph
- Hour Run, ON Hour, Number of Interruptions
- User Assignable Screens
- Back depth 51mm without option / 70mm with option
- Various interface options like Modbus RS485, Ethernet, BACnet and USB
- Compliance to International safety standard IEC 61010-1-2001
- Optional feature of data logging with real time stamping
- Active energy accuracy 0.2s as per IEC 62053-22



Technical Specifications

Display	
Display type	Back-lit LCD display - 4 Line 4 Digit with a separate 9 digit energy counter
Dimensions	96 x 96 x 57mm
Update Rate	1 sec approx
Interface	
Relay (optional)	2 outputs (250 VAC, 5 A AC; 30VDC, 5A DC)
Modbus (optional)	RS485, max. 1200m
Ethernet (optional)	Ethernet access on Modbus TCP/IP Protocol
BACnet (Optional)	BACnet IP with BACnet protocol version 12
USB interface (optional)	Isolated USB Interface on Modbus
Impulse LED	For energy testing
Conforms standards	
EMC	IEC 61326-1: 2012
Immunity	IEC 61000-4-3 10V/m – Level 3 industrial Low level
Safety	IEC 61010-1-2001
IP for water & dust	IEC60529
Pollution degree	2
Installation category	III
High Voltage Test	Input+Aux Vs Surface : 4kV RMS, 50Hz, 1min Input Vs Remaining Circuit : 3.3kV RMS, 50Hz, 1min
Model	
Number of parameters measured	85
System	3Ph 4W / 3Ph 3W / 1Ph 2W
Input Details	
Input Voltage	
Nominal input voltage (AC RMS)	L-L 100 - 600V (L-N 57.5 - 346.42 V)
PT primary values	100VLL - 1200kVLL (on-site programmable)
Maximum continuous input voltage	120% of nominal value

ZAM LC60

DIGITAL POWER MONITORING METER – LOAD ANALYSER

Input Current	
Nominal input current	1A/5A AC RMS
CT secondary values	1A & 5A (on-site programmable)
CT primary values	1A...9999A
Maximum continuous input current	120% of nominal value
Operating Measuring Range	
Voltage (of rated value)	20...120%
Current (of rated value)	1...200%
Frequency	45...66Hz
Power Factor	0.5 Lag...1...0.8 Lead
Auxiliary Supply	
Higher Auxiliary supply range	100-550V AC/DC (230V AC/DC nominal)
Lower Auxiliary supply range	12-60V AC/DC (24 V AC /48 V DC nominal)
Aux Supply frequency	45 to 65 Hz range
VA Burden (approx.)	
Nominal input voltage burden	< 0.3VA approx. per phase(at nominal 240V)
Nominal input current burden	< 0.3 VA approx. per phase
Auxiliary supply burden	< 6VA approx. with add on card
	< 8 VA approx. with Ethernet card
Overload Withstand	
Voltage	2x rated value for 1 sec, repeated 10 times at 10 second intervals
Current	20 x rated value for 1 second , repeated 5 times at 5 minute intervals
Accuracy	
Voltage	± 0.2% of Nominal value
Current	± 0.2% of Nominal value
Frequency	± 0.2% of mid frequency
Active Power	± 0.2% of Nominal value
Re-Active Power	± 1.0% of Nominal value
Apparent Power	± 0.2% of Nominal value
Active Energy (kWh)	Class 0.2s as per IEC 62053- 22
Re-Active Energy (kVAh)	Class 2 as per IEC 62053 - 23
Apparent Energy (kVAh)	Class 1
Power Factor	±3°
Total Harmonic Distortion	±3%
Reference Conditions for Accuracy	
Reference temperature	23°C +/- 2°C
Input frequency	50/60 Hz ± 2%
Input Waveform	Sinusoidal(distortion factor 0.005)
Auxiliary supply frequency	50/60 Hz ± 1%
Voltage range	50%.....100% of nominal value
Total Harmonic distortion	50% up to 15th Harmonics 10% up to 31st Harmonics (Current range 20%...100% of nominal value)
Environmental	
Operating temperature	-20 to +70°C
Storage temperature	-25 to +75°C
Relative humidity	0... 95 % RH (non condensing)
Warm up time	Minimum 3 minute
Enclosure	IP 20 (Terminal side) and IP50(Front side)

ZAM LC60

DIGITAL POWER MONITORING METER – LOAD ANALYSER

Parameter Measurement

System-wise parameter measurement				
Sr.No.	Parameter	3Ph 4W	3Ph 3W	1Ph 2W
1	System Volts	√	√	√
2	System Current	√	√	√
3	Volts L1 – N	√	–	–
4	Volts L2 – N	√	–	–
5	Volts L3 – N	√	–	–
6	Volts L1 – L2	√	√	–
7	Volts L2 – L3	√	√	–
8	Volts L3 – L1	√	√	–
9	Current L1	√	√	–
10	Current L2	√	√	–
11	Current L3	√	√	–
12	Neutral Current	√	–	–
13	Frequency	√	√	√
14	System Active Power (kW)	√	√	√
15	Active Power L1 (kW)	√	–	–
16	Active Power L2 (kW)	√	–	–
17	Active Power L3 (kW)	√	–	–
18	System Re-active Power (kVAr)	√	√	√
19	Re-active Power L1 (kVAr)	√	–	–
20	Re-active Power L2 (kVAr)	√	–	–
21	Re-active Power L3 (kVAr)	√	–	–
22	System Apparent Power (kVA)	√	√	√
23	Apparent Power L1 (kVA)	√	–	–
24	Apparent Power L2 (kVA)	√	–	–
25	Apparent Power L3 (kVA)	√	–	–
26	System Power Factor	√	√	√
27	Power Factor L1	√	–	–
28	Power Factor L2	√	–	–
29	Power Factor L3	√	–	–
30	System Phase Angle	√	√	√
31	Phase Angle L1	√	–	–
32	Phase Angle L2	√	–	–
33	Phase Angle L3	√	–	–
34	Import kWh ¹	√	√	√
35	Export kWh ¹	√	√	√
36	Inductive kVArh ¹	√	√	√
37	Capacitive kVArh ¹	√	√	√
38	kVAh ¹	√	√	√
39	Inductive Var Demand	√	√	√
40	Capacitive Var Demand	√	√	√
41	Current Demand	√	√	√
42	KVA Demand	√	√	√
43	KW Import Demand	√	√	√
44	KW Export Demand	√	√	√

ZAM LC60

DIGITAL POWER MONITORING METER – LOAD ANALYSER

45	Max Current Demand	√	√	√
46	Max KVA Demand	√	√	√
47	Max KW Import Demand	√	√	√
48	Max KW Export Demand	√	√	√
49	Max Inductive Var Demand	√	√	√
50	Max Capacitive Var Demand	√	√	√
51	Run Hour	√	√	√
52	On Hour	√	√	√
53	Number of Interruptions	√	√	√
54	Phase Reversal Indication	√	-	-
55	Current Reversal Indications	√	-	√
56	RPM	√	√	√
57	Phase Absent Indication	√	-	√
58	System Voltage THD	√	√	√
59	THD Volts L1	√	√	-
60	THD Volts L2	√	√	-
61	THD Volts L3	√	√	-
62	System Current THD	√	√	√
63	THD Current L1	√	√	√
64	THD Current L2	√	-	√
65	THD Current L3	√	√	√
66	THD Current L3	√	√	√
67	Individual Harmonics of VI1 (Up to 31st Harmonics)	√	√	√
68	Individual Harmonics of VI2 (Up to 31st Harmonics)	√	√	-
69	Individual Harmonics of VI3 (Up to 31st Harmonics)	√	√	-
70	Individual Harmonics of II1 (Up to 31st Harmonics)	√	√	√
71	Individual Harmonics of II2 (Up to 31st Harmonics)	√	-	-
72	Individual Harmonics of II3 (Up to 31st Harmonics)	√	√	-
73	Old Import Active Energy ²	√	√	√
74	Old Export Active Energy ²	√	√	√
75	Old Inductive Reactive Energy ²	√	√	√
76	Old Capacitive Reactive Energy ²	√	√	√
77	Old Apparent Energy ²	√	√	√
78	Old Run Hour ²	√	√	√
79	Old On Hour ²	√	√	√
80	Old Max kW Import Demand ²	√	√	√
81	Old Max kW Export Demand ²	√	√	√

ZAM LC60

DIGITAL POWER MONITORING METER – LOAD ANALYSER

82	Old Max Var Inductive Demand ²	√	√	√
83	Old Max Var Capacitive Demand ²	√	√	√
84	Old Max VA Demand ²	√	√	√
85	Old Max A Demand ²	√	√	√

Note: 1. Energy on display is auto ranging & unit for Energy parameters on modbus are dependent on CT PT ratio or unit selected by user.
2. Parameters are available only on modbus.

Connection Diagram and Installation

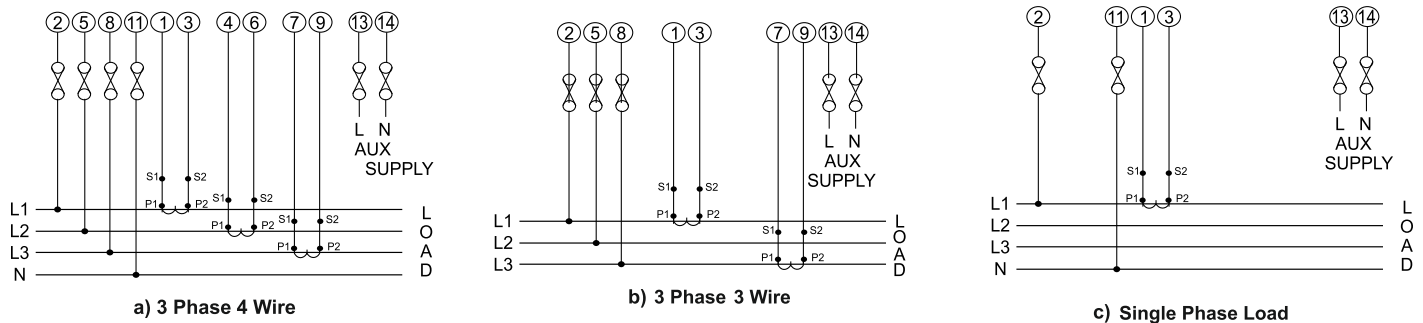

Dimensions

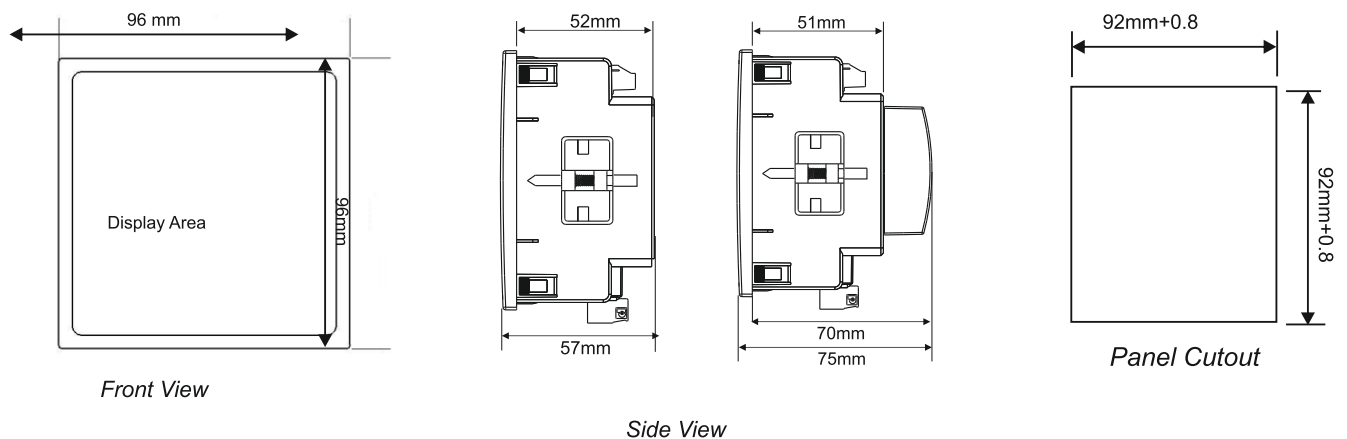

ZAM LC60

DIGITAL POWER MONITORING METER – LOAD ANALYSER

Ordering Information

Model	(√)
ZAM LC60	
Auxiliary Supply	
100 - 550V AC/DC	
12 - 60V AC/DC	
Option	
Modbus RS485 + 2 Pulse Output	
Ethernet Modbus (TCP/IP)	
Ethernet - Data logging	
Modbus RS485 + 2 Pulse Output + Data logging + USB	
BACnet	

Example – ZAM LC60, 12 - 60V AC/DC, Modbus RS485 + 2 Pulse Output

Ziegler

Redefine Innovative Metering

Ziegler Instrumentation UK Ltd.

Central Buildings, Woodland close old woods Trading Estate, Torquay Devon, TQ2 7BB, United Kingdom
+441803 616 800 | info@ziegler-instrument.com | ziegler-instrument.com