

Ziegler

Redefine Innovative Metering

Technical Datasheet

ZPC PC12 | PC08

POWER FACTOR CONTROLLER

ZPC PC12 | PC08

POWER FACTOR CONTROLLER

Power factor controller for reactive power compensation. It controls external reactive power element (preferably a capacitor) to meet reactive demand of load.

ZPC PC12 – 144 x 144 mm, Intelligent control with 6 / 8 / 12 Relay Output

ZPC PC08 – 96 x 96 mm, Intelligent control with 4 / 6 / 8 Relay Output

Product Features

- 16 x 2 LCD display
- Onsite fully programmable : Target PF, No. of Banks, Connecting & Disconnecting time, kVAr Value & Switching threshold
- 1 Relay output (Over V & I, harmonics V & I, Under V & I, Frequency faults, Over/under compensation)
- Measure & display voltage, current, frequency, power, energy, demand, % THD & Individual Harmonics up to 31, RPM, Run hours, On hours, No. of interruption
- Storage of Min Max (V, I & P) & Display Bank Switching Count / Operation Time / Value
- Accuracy Class : 1%
- System Fault(PF, Bank Status)
- RTC (Real Time Clock) – Optional
- MODBUS RS 485 communication – Optional



Technical Specifications

Input Voltage	
Nominal Input Voltage	240 V (30V – 550VAC)
Nominal Frequency	50 or 60 Hz
Nominal input Voltage burden	< 0.2 VA approx. per phase
Overload Capacity	2 x UN for 1 second, repeated 10 times at 10 second intervals
Input Current	
Nominal Input Current	0-1 / 0-5 A AC (2 mA measuring starting current , 10 mA operating current , Max 6 Amp)
Nominal Frequency	50 or 60 Hz
Nominal input Voltage burden	< 0.6 VA approx. per phase
Overload Capacity	1.2 x IN continuously 20 x IN for 1 second, repeated 5 times at 5 minute intervals

Output Data	
No. of Outputs	4 / 6 / 8 – ZPC PC08, 6 / 8 / 12 – ZPC PC12
Alarm output	1
Target PF range	0.8 Ld to 0.8 Lg
Switching Threshold	30 to 100 %
Switch-in or Off -time (Connecting Time / Disconnecting Time)	10 to 1800 Sec
Discharge time	60 to 1800 Sec

POWER FACTOR CONTROLLER

Protection & Alarms	Limits	Default Trip values	Restore values
Under-voltage	75 - 90 % of V nom	85%	3% + trip value
Over-voltage	105 -115 % of Vnom	115%	2% - trip value
Under-Frequency	2 -10 % of Freq-Nom	6%	1 % of Freq-Nom
Over-Frequency	2 -10 % of Freq-Nom	6%	1 % of Freq-Nom
Under-current	1 - 3 % of CT primary	2%	1% of CT primary + trip value
Over-current	60 -120 % of CT primary	110%	1% of CT primary - trip value
V-thd	1 - 25 %	7%	2%
I-thd	1 - 99 %	7%	2%
Temperature	-	60°C	55°C
Overcompensation / Out of bank	Threshold x Min CkVAr	Threshold x Min CkVAr	Demand kVAr > Min CkVAr

Power Supply

Auxiliary Supply	110 V AC to 550 VAC (Burden : < 13 VA approx) 40 to 70 Hz
------------------	--

Display Parameters

- Voltage , Current & Frequency
- Power (kW, kVAr & KVA)
- Power Factor & Bank Status
- THD % & Individual Harmonics up to 31st
- Energy (kWh, kVArh & kVAh)
- Demand (A, kW & kVA)
- System Fault(PF, Bank Status)
- Min Max (V, I & P)
- Bank Switching Count / Operation Time / Value

Onsite Programmable

- PFC parameters :
- ✓ Number of banks
- ✓ Bank kVAr value
- ✓ Connecting & disconnecting time
- ✓ Discharge time
- ✓ Maximum switching kVAr
- ✓ Switching threshold,
- ✓ Target PF
- System Parameters : Voltage & Current (CT/PT ratio)
- Display : Contrast, Auto Scroll, Backlit

POWER FACTOR CONTROLLER

Accuracy	
Voltage	± 0.5% of Nominal value
Current	± 0.5% of Nominal value
Frequency	± 0.15% of mid frequency
Active Power	± 1.0 % of Nominal value
Re-Active Power	± 1.0 % of Nominal value
Apparent Power	± 1.0 % of Nominal value
Active energy (kWh)	± 1.0 %
Re Active energy (kVArh)	± 1.0 %
Apparent energy (kVAh)	± 1.0 %
Total Harmonic Distortion	± 1.0 % of Applied value
Reference conditions for Accuracy	
Ambient temperature	23°C +/- 2°C
Input signal frequency	50 or 60Hz
Input waveform	Sinusoidal
Auxiliary supply voltage	Rated Value ±1%
Auxiliary supply frequency	Rated Value ±1%
Voltage Range	50... 100% of Nominal Value. 60... 100% of Nominal Value for THD.
Current Range	10... 100% of Nominal Value. 20... 100% of Nominal Value for THD.
Power	Cos phi / sin phi = 1 for Active / Reactive Power & Energy. 10... 100% of Nominal Current & 50... 100% of Nominal Voltage.
Temperature coefficient :(for rated value range of use (0...50°C))	0.05%/°C for Voltage (50... 120% of rated value) and 0.05%/°C for Current (10... 120% of rated value)

Applicable Standards	
EMC	IEC 61326-1:2012, Table 2
Accuracy	IEC 62053-21
IP for water & dust	IEC60529
Pollution degree	2
Installation category	III
High Voltage Test	2.2 kV AC, 50Hz for 1 minute between all electrical circuits

Environmental	
Nominal range of use	-10 to +60°C
Storage temperature	-20 to +65°C
Relative humidity of annual mean	0... 90% non condensing
Warm up time	Minimum 3 minute

Electrical Connections

1. ZPC PC12

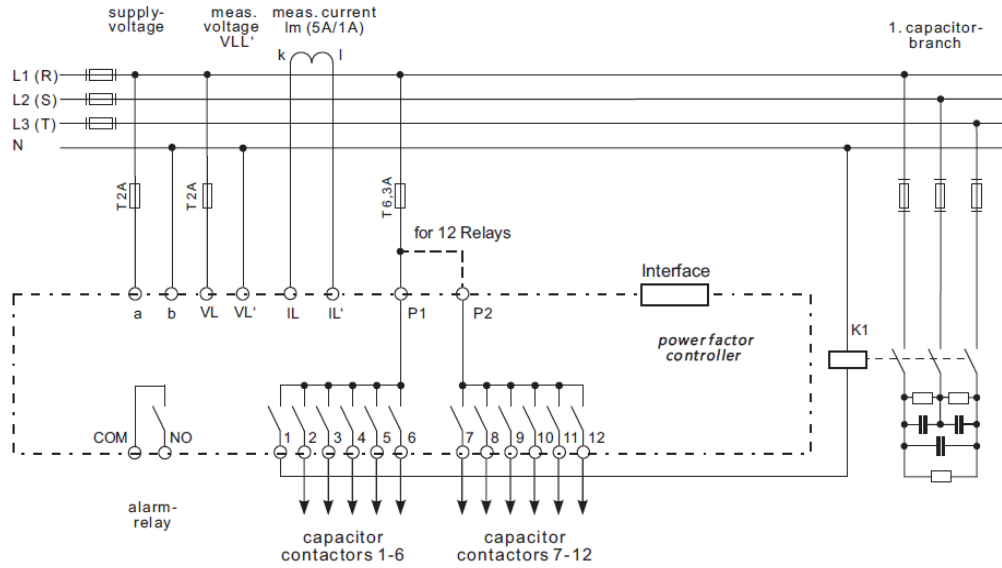

2. ZPC PC08

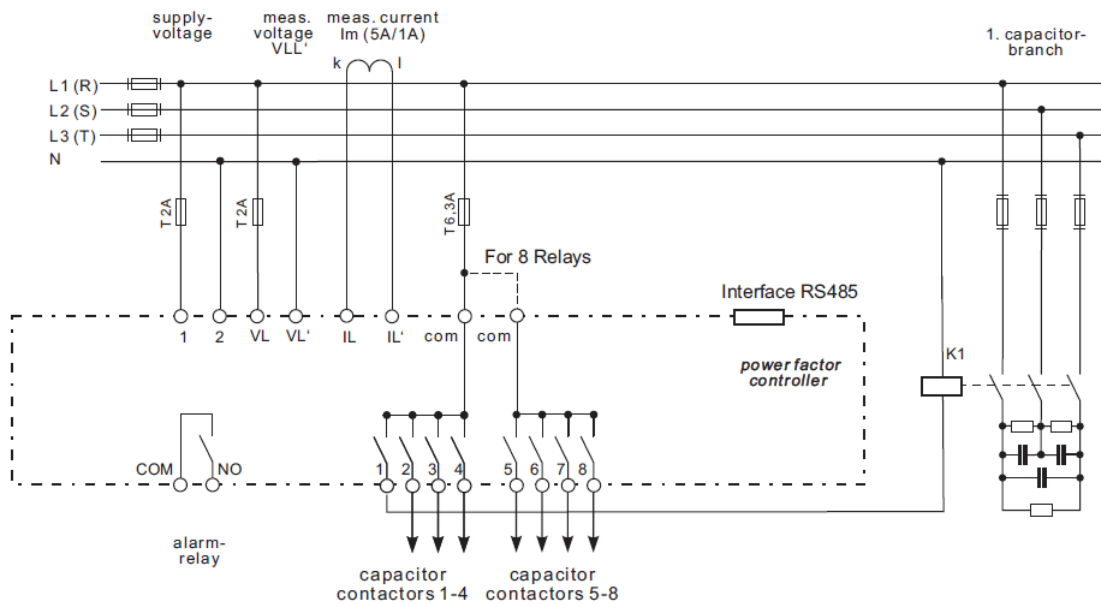

ZPC PC12 | PC08

POWER FACTOR CONTROLLER

Dimensions (In mm)

1. ZPC PC12 – 144 x 144mm

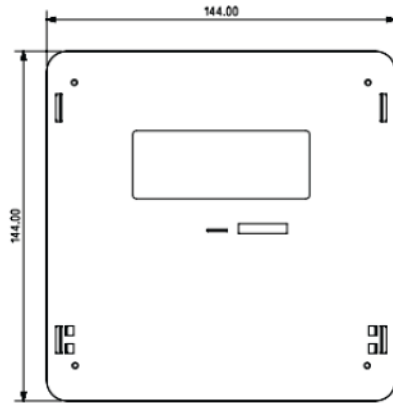

FRONT VIEW

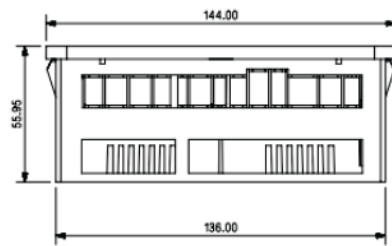

SIDE VIEW

2. ZPC PC08 – 96 x 96mm

Without Add-on

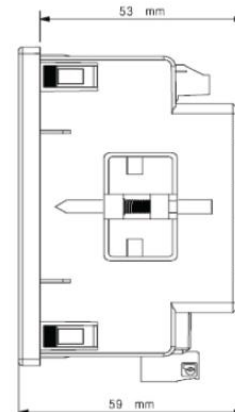
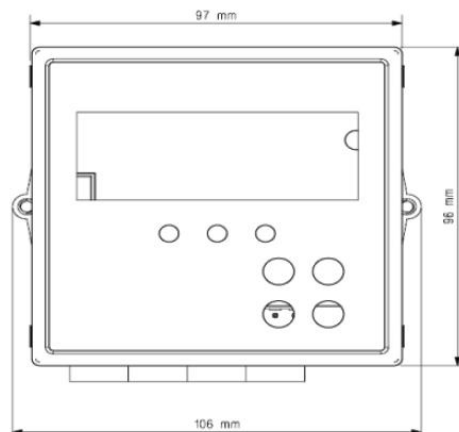

With Add-on

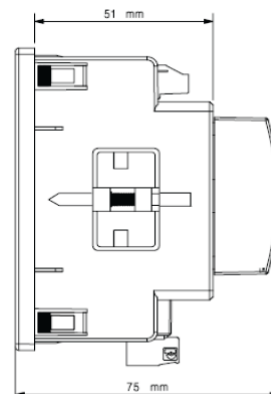
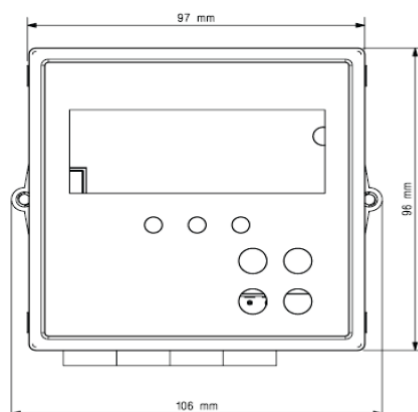

ZPC PC12 | PC08

POWER FACTOR CONTROLLER

Ordering Information	(√)
Model	
ZPC PC12	
ZPC PC08	
Relay Output	
4 Steps (Applicable for PC08 only)	
6 Steps	
8 Steps	
12 Steps	
Optional Modules	
MODBUS RS 485 communication	
RTC	

Ziegler

Redefine Innovative Metering

Ziegler Instrumentation UK Ltd.

Central Buildings, Woodland close old woods Trading Estate, Torquay Devon, TQ2 7BB, United Kingdom
+441803 616 800 | info@ziegler-instrument.com | ziegler-instrument.com