

Ziegler

Redefine Innovative Metering

Technical Datasheet

ZAM LC80

DIGITAL POWER MONITORING METER – LOAD ANALYSER

ZAM LC80

DIGITAL POWER MONITORING METER – LOAD ANALYSER

ZAM LC80 Power Monitoring meter which can measure important AC electrical parameters in 1 ϕ and 3 ϕ systems. It measures all electrical parameters including Individual Phase wise energy, Individual harmonics, %THD ,Demand, RPM, Neutral current, Run-hours,On-hours and No. of interruptions.

Product Features

- On-site fully programmable User Assignable Screens
- THD and Individual Harmonic measurement up to 63rd harmonics
- Line wise and System wise Energy
- On Display Status Indication of DI, DO, Communication
- Various interface options like Modbus RS485, Ethernet and USB
- Compliance to International safety standard IEC 61010-1-2001
- 4 Digital Input configure as Status, Tariff and Pulse counter (Optional)
- Active energy accuracy 0.2s as per IEC 62053-22 & 0.2 as per IEC 61557-12
- Inbuilt 8MB data-logging Memory : Event, Time, Load Profile based Logging
- Multi Tariff Facility - 8 Tariff based on digital input & 6 Energy parameters
- Health Monitoring of Three Phase Load, Prepaid Cost Based Energy Tripping
- Min Max values of Voltage, Current, Power, Power factor, Phase Angle, Frequency
- True RMS measurement with a sampling rate of 128 samples rate per cycle upto 63 Harmonic



Technical Specifications

Display	
Display type	Back-lit LCD display - 4 Line 4 Digit with a separate 9 digit energy counter
Dimensions	96 x 96 x 57mm / 73mm / 92mm
Update Rate	1 sec approx
Interface	
Relay (optional)	2 outputs (250 VAC, 5 A AC; 30VDC, 5A DC)
Modbus (optional)	RS485, max. 1200m
Ethernet (optional)	Ethernet access on Modbus TCP/IP Protocol
4 Digital Input (optional)	20... 300 VAC / 10... 60 VDC, Optical couplers, Min pulse width 10ms, Min length between 2 pulses 18ms, VA < 0.25VA at 240 VAC
Impulse LED	For energy testing
Conforms standards	
EMC	IEC 61326-1: 2012 Table 2
Immunity	IEC 61000-4-2, -3, -4, -5, -6, -8, -11
Safety	IEC 61010-1-2001
IP for water & dust	IEC60529
Pollution degree	2
Installation category	III
High Voltage Test	All Circuit Vs Surface : 4kV RMS, 50Hz, 1min Input/Aux/DI/DO Vs Remaining Circuit : 3.3kV RMS, 50Hz, 1min
Model	
	ZAM LC80
System	3Ph 4W / 3Ph 3W / 1Ph 2W
Input Details	
Input Voltage	
Nominal input voltage (AC RMS)	100VLL to 600 VLL AC RMS (57.5VL-N - 346.42 VL-N)
PT primary values	100VLL - 1200kVLL (on-site programmable)
Maximum continuous input voltage	120% of nominal value

ZAM LC80

DIGITAL POWER MONITORING METER – LOAD ANALYSER

Input Current	
Nominal input current	1A/5A AC RMS (on-site programmable)
CT primary values	1A...9999A
Maximum continuous input current	200% of nominal value
Operating Measuring Range	
Voltage (of rated value)	20...120%
Current (of rated value)	1...200%
Frequency	40...70Hz
Power Factor	0.5 Lag...1. 0.8 Lead
Auxiliary Supply	
Higher Auxiliary supply range	100-550V AC/DC and 100-320V AC/DC (as per IEC 61557 -12)
Lower Auxiliary supply range	12-60V AC/DC (24 V AC /48 V DC nominal)
Aux Supply frequency	45 to 65 Hz range
VA Burden (approx.)	
Nominal input voltage burden	< 0.3VA approx. per phase(at nominal 240V)
Nominal input current burden	< 0.3 VA approx. per phase
Auxiliary supply burden	< 6VA approx. with add on card & <8VA approx. With ethernet card < 10 VA approx. with RS 485 + Ethernet card
Overload Withstand	
Voltage	2x rated value for 1 sec, repeated 10 times at 10 second intervals
Current	20 x rated value for 1 second , repeated 5 times at 5 minute intervals
Accuracy	
Voltage	± 0.2% of Nominal value
Current	± 0.2% of Nominal value
Frequency	± 0.1% of mid frequency
Active Power	± 0.2% of Nominal value
Re-Active Power	± 1.0% of Nominal value
Apparent Power	± 0.2% of Nominal value
Active Energy (kWh)	Class 0.2s as per IEC 62053- 22 & Class 0.2 as per IEC 61557-12
Re-Active Energy (kVArh)	Class 2 as per IEC 62053 - 23 & as per IEC 61557-12
Apparent Energy (kVAh)	Class 1 as per IEC 61557-12
Power Factor	±3°
Total Harmonic Distortion & Individual	±5% (Upto 63 rd)
Reference Conditions for Accuracy	
Reference temperature	23°C +/- 2°C
Input frequency	50/60 Hz ± 2%
Input Waveform	Sinusoidal(distortion factor 0.005)
Auxiliary supply frequency	50/60 Hz ± 1%
Voltage range	50%.....100% of nominal value
Total Harmonic distortion	50% up to 63 rd Harmonics (Vn) 200% up to 63 rd Harmonics(In) (Current range 20%...100% of nominal value)
Environmental	
Operating temperature	-20 to +70°C
Storage temperature	-25 to +85°C
Relative humidity	0... 95 % RH (non condensing)
Warm up time	Minimum 3 minute
Enclosure	IP 20 (Terminal side) and IP54(Front side)

Parameter Measurement

Sr No	Parameters	3 Phase 4Wire	3Phase 3Wire	1Phase 2Wire
1.	System Import Active Energy ¹	√	√	√
2.	L1,L2,L3 Import Active Energy ¹	√	✘	✘
3.	System Export Active Energy ¹	√	√	√
4.	L1,L2,L3 Export Active Energy ¹	√	✘	✘
5.	System Total Active Energy ¹	√	√	√
6.	L1,L2,L3 Total Active Energy ¹	√	✘	✘
7.	System Inductive Reactive Energy ¹	√	√	√
8.	L1,L2,L3 Inductive Reactive Energy ¹	√	✘	✘
9.	System Capacitive Reactive Energy ¹	√	√	√
10.	L1,L2,L3 Capacitive Reactive Energy ¹	√	✘	✘
11.	System Total Reactive Energy ¹	√	√	√
12.	L1,L2,L3 Total Reactive Energy ¹	√	✘	✘
13.	System Apparent Energy ¹	√	√	√
14.	L1,L2,L3 Apparent Energy ¹	√	✘	✘
15.	System Active Power (kW) ³	√	√	√
16.	L1,L2,L3 Active Power (kW) ³	√	✘	✘
17.	System Total Re-active Power (kVAr) ³	√	√	√
18.	L1,L2,L3 Total Re-active Power (kVAr) ³	√	✘	✘
19.	System Fundamental Re-active Power (kVAr) ²	√	√	√
20.	L1,L2,L3 Fundamental Re-active Power (kVAr) ²	√	✘	✘
21.	System Distorted Re-active Power (kVAr) ²	√	√	√
22.	L1,L2,L3 Distorted Re-active Power (kVAr) ²	√	✘	✘
23.	System Apparent Power (kVA) ³	√	√	√
24.	L1,L2,L3 Apparent Power (kVA) ³	√	✘	✘
25.	System Power Factor	√	√	√
26.	L1,L2,L3 Power Factor	√	✘	✘
27.	System Displacement Power Factor	√	√	√
28.	L1,L2,L3 Displacement Power Factor	√	✘	✘
29.	System Reactive Power Factor	√	√	√
30.	L1,L2,L3 Reactive Power Factor	√	✘	✘
31.	System LF Factor SgnQ(1-(P/S))	√	√	√
32.	L1,L2,L3 LF Factor SgnQ(1-(P/S))	√	✘	✘
33.	System Phase Angle ³	√	√	√
34.	L1,L2,L3 Phase Angle ³	√	✘	✘
35.	Current Demand	√	√	√
36.	kVA Demand	√	√	√
37.	Import kW Demand	√	√	√
38.	Export kW Demand	√	√	√
39.	Inductive Var Demand	√	√	√
40.	Capacitive Var Demand	√	√	√
41.	Max Current Demand	√	√	√
42.	Max kVA Demand	√	√	√
43.	Max Import kW Demand	√	√	√
44.	Max Export kW Demand	√	√	√
45.	Max Inductive Var Demand	√	√	√
46.	Max Capacitive Var Demand	√	√	√
47.	Run Hour	√	√	√
48.	On Hour	√	√	√
49.	Number of Interruptions	√	√	√
50.	System Voltage ³	√	√	√
51.	L1,L2,L3 Voltage ³	√	✘	✘
52.	L12,L23,L31 Voltage ³	√	√	✘

DIGITAL POWER MONITORING METER – LOAD ANALYSER

Sr No	Parameters	3 Phase 4Wire	3Phase 3Wire	1Phase 2Wire
53.	System Voltage THD	√	√	√
54.	L1-L2-L3 Voltage THD	√	√	✘
55.	System Current ³	√	√	√
56.	L1-L2-L3 Current ³	√	√	✘
57.	System Current THD	√	√	√
58.	L1-L2-L3 Current THD	√	√	✘
59.	Individual Harmonics VL1(Up to 63rd Harmonics)	√	√	√
60.	Individual Harmonics VL2 (Up to 63rd Harmonics)	√	√	✘
61.	Individual Harmonics VL3 (Up to 63rd Harmonics)	√	√	✘
62.	Individual Harmonics IL1(Up to 63rd Harmonics)	√	√	√
63.	Individual Harmonics IL2(Up to 63rd Harmonic)	√	✘	✘
64.	Individual Harmonics IL3(Up to 63rd Harmonics)	√	√	✘
65.	Neutral Current (Calculated)	√	✘	✘
66.	Frequency ³	√	√	√
67.	RPM	√	√	√
68.	Phase Sequence Indication	√	√	✘
69.	Current Reversal Indication	√	✘	√
70.	Phase (V-I) Absent Indication	√	✘	✘
71.	Tariff Source 1 Energy Count	√	√	√
72.	Tariff Source 2 Energy Count	√	√	√
73.	Tariff Source 3 Energy Count	√	√	√
74.	Tariff Source 4 Energy Count	√	√	√
75.	Tariff Source 5 Energy Count	√	√	√
76.	Tariff Source 6 Energy Count	√	√	√
77.	Old Max A Demand ²	√	√	√
78.	Old Max VA Demand ²	√	√	√
79.	Old Max kW Import Demand ²	√	√	√
80.	Old Max kW Export Demand ²	√	√	√
81.	Old Max Var Inductive Demand ²	√	√	√
82.	Old Max Var Capacitive Demand ²	√	√	√
83.	Old System Import Active Energy ²	√	√	√
84.	Old L1-L2-L3 Import Active Energy ²	√	✘	✘
85.	Old System Export Active Energy ²	√	√	√
86.	Old L1-L2-L3 Export Active Energy ²	√	✘	✘
87.	Old System Inductive Reactive Energy ²	√	√	√
88.	Old L1-L2-L3 Inductive Reactive Energy ²	√	✘	✘
89.	Old System Capacitive Reactive Energy ²	√	√	√
90.	Old L1-L2-L3 Capacitive Reactive Energy ²	√	✘	✘
91.	Old System Apparent Energy ²	√	√	√
92.	Old L1-L2-L3 Apparent Energy ²	√	✘	✘
93.	Old Run Hour ²	√	√	√
94.	Old On Hour ²	√	√	√
95.	Old Number of Interruptions ²	√	√	√
96.	VLN Unbalance ²	√	✘	✘
97.	VLL Unbalance ²	√	√	✘
98.	Current Unbalance ²	√	√	✘

Note: 1. Energy on display is auto ranging & unit for Energy parameters on modbus are dependent on CT PT ratio or unit selected by user.

2. Parameters are available only on modbus.

3. Min-Max parameters are also available.

ZAM LC80

DIGITAL POWER MONITORING METER – LOAD ANALYSER

Connection Diagram and Installation

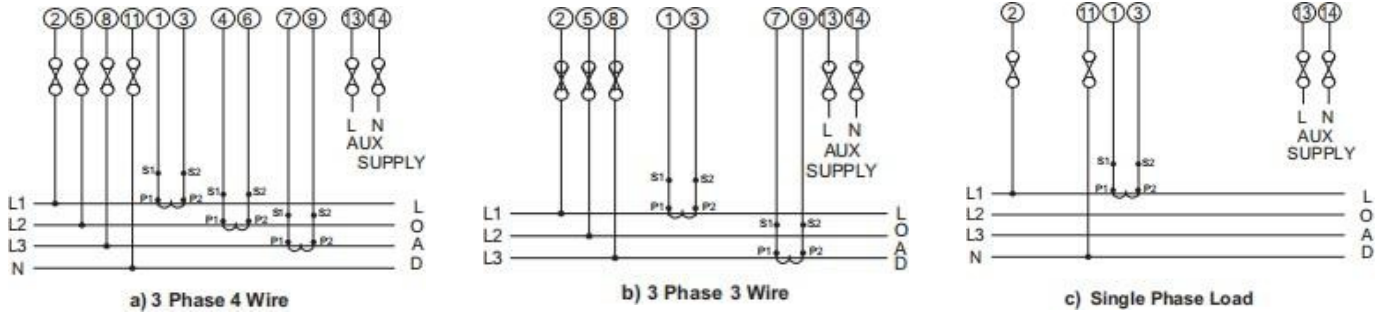

Dimensions

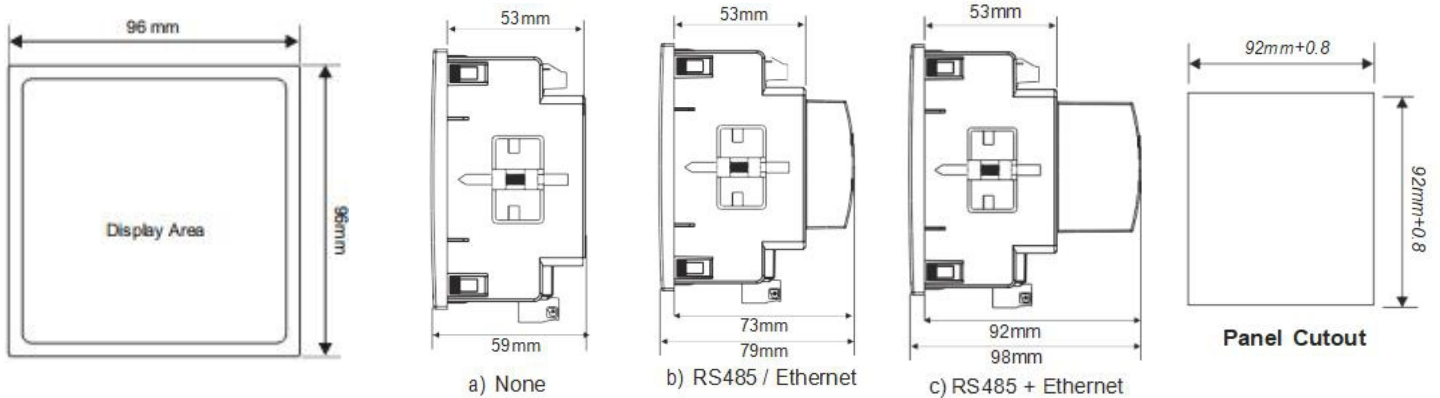

Wiring and connection Instruction

Solid with Pin type lugs (sq. mm)	1 to 2.5
Stranded with pin types lugs (sq. mm)	1 to 2.5
Torque value (Nm)	
1. Aux and Voltage terminals	0.5 to 0.6
2. Current Terminals	0.4 to 0.5
3. RS485, DI and Relay terminals	0.3 to 0.4
Length available for lug entry in terminal (mm)	9.5

Note:

1. It is recommended that the wires used for connections to the instrument should have lugs soldered at the end i.e., the connections should be made with Lugged wires for secure connections.
2. For MODBUS B refers to positive, A refers to Negative and G refers to ground.

ZAM LC80

DIGITAL POWER MONITORING METER – LOAD ANALYSER

Ordering Information

Model	(√)
ZAM LC80	
Auxiliary Supply	
100 - 550V AC/DC	
12 - 60V AC/DC	
Option	
Modbus RS485	
Ethernet Modbus (TCP/IP)	
Ethernet + 2 Pulse Output + 4 Digital Input	
Modbus RS485 + 2 Pulse Output + 4 Digital Input	
Modbus RS485 + Ethernet + 2 Pulse Output + 4 Digital Input	

Example – ZAM LC80, 12 - 60V AC/DC, Modbus RS485 + Ethernet + 2 Pulse Output + 4 Digital Input, Datalogging, USB

Ziegler

Redefine Innovative Metering

Ziegler Instrumentation UK Ltd.

Central Buildings, Woodland close old woods Trading Estate, Torquay Devon, TQ2 7BB, United Kingdom

+441803 616 800 | info@ziegler-instrument.com | ziegler-instrument.com