

# Ziegler

Redefine Innovative Metering

## Technical Datasheet

Three-Phase Direct Connected Energy Meter  
ZAM DN4U-MD/ZAM DN4U-4T

---

# Energy Meter

## ZAM DN4U

### Overview :

**ZAM DN4U** is a modern Three Phase Direct Connected Energy Meter designed for intended use in residential, commercial and light industrial Electrical Energy Metering. The meter is engineered using advanced microcontroller technology and is suitable for electrical parameter measurement and monitoring in 3 Phase 4 Wire, 3 Phase 3 Wire and 1 Phase 2 Wire Networks. It supports maximum 100 A current measurement on direct connection. It supports Tariff Counters selectable via Digital Input. It displays parameters on bright intuitive LCD and also has Pulse Outputs and Impulse LED for energy monitoring. It has inbuilt industry standard MODBUS RTU for remote monitoring. Meter housing is standard Din Rail Mount that allows ease of installation.

### Product Features :

- **Direct Connection Meter:**  
ZAM DN4U can safely measure 100A maximum current on direct connection, eliminating the use of expensive external CT for high current networks. Meter is also self-powered thus offer simplified connections.
- **Measured Electrical Parameters:**  
ZAM DN4U is primarily for bidirectional Active, Reactive and Apparent Energy measurement but it also accurately measures important electrical parameters like TRMS Voltage, TRMS Current, Frequency, Active, Reactive and Apparent Power, and Power Factor in Three Phase and Single Phase Networks. The measured parameters can be viewed on display and MODBUS for remote viewing.
- **Demand :**  
The Demand parameter for Active Power (Import/Export), Reactive Power (Import/Export), Apparent Power and Current are calculated as per configurable Demand Integration time.
- **Pulse Outputs (SO) :**  
**ZAM DN4U** has two opto-isolated pulse outputs that can be configured for any one of the Active (Import/Export), Reactive (Import/Export) & Apparent Energy parameter. The pulse width and rate of pulse out is onsite programmable.
- **Impulse LED :**  
The meter has Impulse LED which flash at rate of 1000 impulse per 1 kWh indicating the Active Energy consumption.
- **Digital Input :**  
The meter has two Digital Input (DI) dedicated for selection of four tariff T1, T2, T3 and T4 selection. The opto-isolated DI is rated for a wide range of AC/DC voltage for operation.
- **Front Keys :**  
Three keys are provided for easy navigation and accessibility of different parameters and onsite programming of the meter.
- **Remote Communication ( ZAM DN4U-MD ) :**  
ZAM DN4U-MD provides optional communication based on MODBUS protocol for remote data acquisition of measurement data and configuration. MODBUS parameters Baud rate, device address and parity- stop bits are programmable.



# Energy Meter

## ZAM DN4U

- **LCD :**  
The LCD has bold seven segment digits with bright white backlit for display of measurement parameters. Special symbols, units and bar graph are provided for effective display and easy onsite configuration. Indications for current reversal, communication status, active tariff, digital inputs and pulse outputs status are continuously available on screen. Measurement screen can be set as automatic scrolling or manual scrolling.
  - **Multi tariff :**  
The meter has Tariff Counters for energy accumulation which are selectable via Digital Input. Energy for tariff are Total/Import/Export Active Energy, Total/Import/Export Reactive Energy, Total Apparent Energy.
- Compliance to Standards :**
- National / International Standards are complied  
Accuracy Standard : EN50470-1, 3  
IEC62053-21, 23  
IP for water & dust : IEC 60529  
Plastic Flammability  
Standard : UL 94

### Dimensions Details :

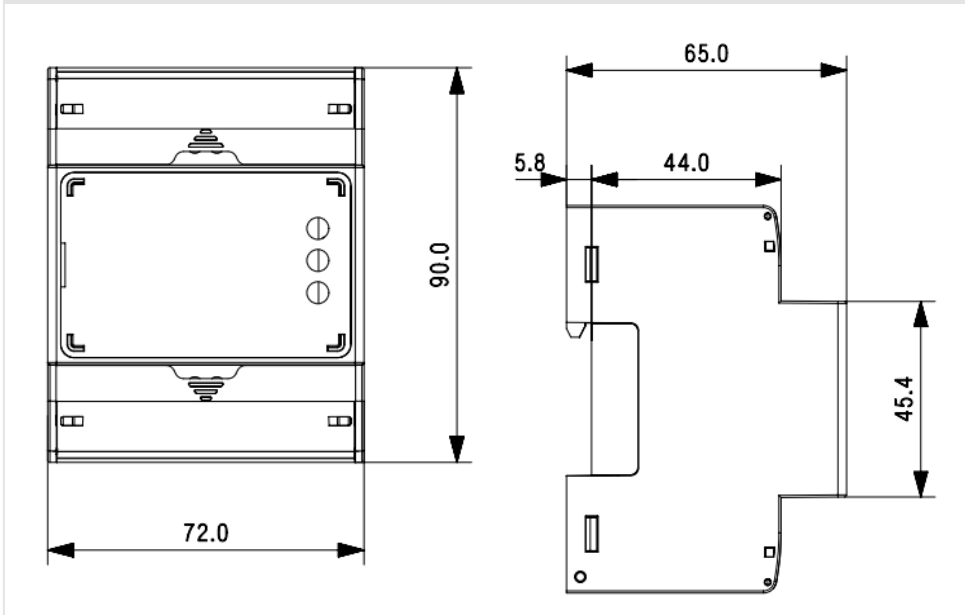

### Technical Specifications :

Input :	
Reference Voltage ( $U_n$ )	230 VLN (400 VLL)
Operating Voltage Range	100 - 289 VLN (173 - 500 VLL)
Power consumption in Voltage Circuit	< 2 W (10 VA) per phase

# Energy Meter

## ZAM DN4U

Current Measurement Parameters	
Starting Current ( $I_{st} = 0.04 \cdot I_{tr}$ )	20 mA
Minimum Current ( $I_{min} = 0.5 \cdot I_{tr}$ )	250 mA
Transitional Current ( $I_{tr}$ )	0.5 A
Reference Current ( $I_{ref} = 10 \cdot I_{tr}$ )	5 A
Maximum Current ( $I_{max} > 50 \cdot I_{tr}$ )	100 A
Operating Current Range	0.25-5 A (100 A)
Short time Over-current	$30 \cdot I_{max}$ for half-cycle at 50 Hz
Power consumption in Current Circuit	<1VA per phase
Frequency	50/60 Hz

### Auxiliary Supply :

Type Self Powered

### Reference Conditions for Accuracy :

Reference Temperature	23°C ± 2°C
Input Voltage	Un ± 1%
Input Waveform	Sinusoidal (distortion factor <2%)
Input Frequency	50 Hz ± 0.3%

### Accuracy :

Active Energy (Import/Export)	Class B as per EN50470-3 Class 1 as per IEC 62053-21
Reactive Energy (Import/Export)	Class 2 as per IEC62053-23
Apparent Energy	± 1.0 %
Voltage	± 0.5% of of range max
Current	± 0.5% of Nominal value
Frequency	± 0.2% of Mid frequency
Active Power	± 1% of range max
Reactive Power	± 1% of range max
Apparent Power	± 1% of range max
Power Factor	±1% of unit
VTHD & ITHD	±4%(THD>=15%)

### Pulse Outputs :

So1 and SO2	Passive Opto-isolated
Contact Ranges	5-27V DC, 27 mA DC (max)
Pulse Duration	60, 100 and 200 millisecond
Pulse Rate	0.01, 0.1, 1, 10, 100, 500 & 1000 pulse per kWh/kVARh
Parameters	Total/ Import/ Export kWh & kVARh

# Energy Meter

## ZAM DN4U

### Impulse LED :

Impulse Rate 1000 pulse per kWh

### Communication Interface :

Protocol	Rs485 MODBUS
Baudrate	4.8 / 9.6 /19.2/38.4/57.6 kbps
Data Width	8
Parity - Stop Bits	None -1 / None -2/ Even -1 / Odd -1
Device Address	1- 247
Response Time	200 millisecond

### Connector Details :

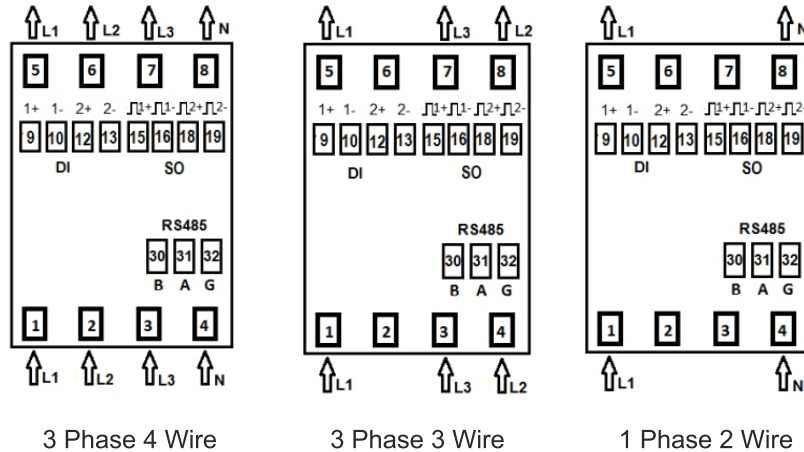

### Display Ranges :

Active Energy	0-999999.99 kWh
Reactive Energy	0-999999.99 kVARh
Apparent Energy	0-999999.99 kVAh
Active Power	0-99999 W
Reactive Power	0-99999 VAR
Apparent Power	0-99999 VA

### Digital Input :

0 V	Low
20... 300 VAC / 10... 60 VDC	High

# Energy Meter

## ZAM DN4U

Installation :	
Installation	Indoor
Enclosure	IP51 (Front)
Housing	(4 Module DIN 43880)
Dimensions	72 mm X 90 mm X 65 mm
Weight	350 gm
Mounting	snap on 35 mm DIN Rail

Safety :	
Safety Standard	According to EN50470
Installation Category	III
Protective Class	II
Pollution Degree	2
AC Voltage Test	4kV for 1 Minute
Impulse Voltage Withstand	6 kV (1.2 microsecond waveform)
Housing flame Resistance	Flammability Class V-0 acc to UL-94, Self Extinguishing, Non-Dripping, Free of Halogen

Environmental Conditions :	
Mechanical Environment	M1
Electromagnetic Environment	E2
Operating Temperature	-25°C to +55°C
Storage/Transport Temperature	-40°C to +70°C
Relative Humidity	0... 90% (Non Condensing)

Wiring Guidelines :	
Current Input Wire Size	1 to 25 mm <sup>2</sup>
Current/Voltage Tightening Torque	3 Nm
RS485 / SO / DI Wire Size	0.1 to 2.5 mm <sup>2</sup> (Solid/Stranded with pin type lug)
RS485 / SO / DI Tightening Torque	0.3 to 0.4 Nm

# Energy Meter

## ZAM DN4U

### Measured Parameter

✓ : Available ✗ : Not Available

Sr No	Parameters	3Phase 4Wire	3Phase 3Wire	1Phase 2Wire
1.	Import Active Energy	✓	✓	✓
2.	Export Active Energy	✓	✓	✓
3.	Total Active Energy	✓	✓	✓
4.	Import Reactive Energy	✓	✓	✓
5.	Export Reactive Energy	✓	✓	✓
6.	Total Reactive Energy	✓	✓	✓
7.	Total Apparent Energy	✓	✓	✓
8.	T1 Import Active Energy	✓	✓	✓
9.	T1 Export Active Energy	✓	✓	✓
10.	T1 Total Active Energy	✓	✓	✓
11.	T1 Import Reactive Energy	✓	✓	✓
12.	T1 Export Reactive Energy	✓	✓	✓
13.	T1 Total Reactive Energy	✓	✓	✓
14.	T1 Total Apparent Energy	✓	✓	✓
15.	T1 Partial Import Active Energy	✓	✓	✓
16.	T1 Partial Export Active Energy	✓	✓	✓
17.	T1 Partial Import Reactive Energy	✓	✓	✓
18.	T1 Partial Export Reactive Energy	✓	✓	✓
19.	T2 Import Active Energy	✓	✓	✓
20.	T2 Export Active Energy	✓	✓	✓
21.	T2 Total Active Energy	✓	✓	✓
22.	T2 Import Reactive Energy	✓	✓	✓
23.	T2 Export Reactive Energy	✓	✓	✓
24.	T2 Total Reactive Energy	✓	✓	✓
25.	T2 Total Apparent Energy	✓	✓	✓
26.	T2 Partial Import Active Energy	✓	✓	✓
27.	T2 Partial Export Active Energy	✓	✓	✓
28.	T2 Partial Import Reactive Energy	✓	✓	✓
29.	T2 Partial Export Reactive Energy	✓	✓	✓
30.	T3 Import Active Energy	✓	✓	✓
31.	T3 Export Active Energy	✓	✓	✓
32.	T3 Total Active Energy	✓	✓	✓
33.	T3 Import Reactive Energy	✓	✓	✓
34.	T3 Export Reactive Energy	✓	✓	✓
35.	T3 Total Reactive Energy	✓	✓	✓
36.	T3 Total Apparent Energy	✓	✓	✓
37.	T3 Partial Import Active Energy	✓	✓	✓

# Energy Meter

## ZAM DN4U

### Measured Parameter

✓ : Available ✗ : Not Available

Sr No	Parameters	3Phase 4Wire	3Phase 3Wire	1Phase 2Wire
38.	T3 Partial Export Active Energy	✓	✓	✓
39.	T3 Partial Import Reactive Energy	✓	✓	✓
40.	T3 Partial Export Reactive Energy	✓	✓	✓
41.	T4 Import Active Energy	✓	✓	✓
42.	T4 Export Active Energy	✓	✓	✓
43.	T4 Total Active Energy	✓	✓	✓
44.	T4 Import Reactive Energy	✓	✓	✓
45.	T4 Export Reactive Energy	✓	✓	✓
46.	T4 Total Reactive Energy	✓	✓	✓
47.	T4 Total Apparent Energy	✓	✓	✓
48.	T4 Partial Import Active Energy	✓	✓	✓
49.	T4 Partial Export Active Energy	✓	✓	✓
50.	T4 Partial Import Reactive Energy	✓	✓	✓
51.	T4 Partial Export Reactive Energy	✓	✓	✓
52.	L1, L2, L3 Import Active Energy	✓	✗	✗
53.	L1, L2, L3 Export Active Energy	✓	✗	✗
54.	L1, L2, L3 Total Active Energy	✓	✗	✗
55.	L1, L2, L3 Import Reactive Energy	✓	✗	✗
56.	L1, L2, L3 Export Reactive Energy	✓	✗	✗
57.	L1, L2, L3 Total Reactive Energy	✓	✗	✗
58.	L1, L2, L3 Total Apparent Energy	✓	✗	✗
59.	Partial Import Active Energy	✓	✓	✓
60.	Partial Export Active Energy	✓	✓	✓
61.	Partial Total Active Energy	✓	✓	✓
62.	Partial Import Reactive Energy	✓	✓	✓
63.	Partial Export Reactive Energy	✓	✓	✓
64.	Partial Total Reactive Energy	✓	✓	✓
65.	Partial Total Apparent Energy	✓	✓	✓
66.	Current Max Demand	✓	✓	✓
67.	kVA Max Demand	✓	✓	✓
68.	kW Max Demand	✓	✓	✓
69.	kVar Max Demand	✓	✓	✓
70.	Import kW Max Demand	✓	✓	✓
71.	Export kW Max Demand	✓	✓	✓
72.	Import kVar Max Demand	✓	✓	✓
73.	Export kVar Max Demand	✓	✓	✓
74.	L1, L2, L3 Current Max Demand	✓	✓	✗



# Energy Meter

## ZAM DN4U

### Measured Parameter

✓ : Available ✗ : Not Available

Sr No	Parameters	3Phase 4Wire	3Phase 3Wire	1Phase 2Wire
75.	System Voltage	✓	✓	✓
76.	L1, L2, L3 Voltage	✓	✗	✗
77.	L12, L23, L31 Voltage	✓	✓	✗
78.	System Current	✓	✓	✓
79.	L1, L2, L3 Current	✓	✓	✗
80.	Frequency	✓	✓	✓
81.	System Active Power	✓	✓	✓
82.	L1, L2, L3 Active Power	✓	✗	✗
83.	System Reactive Power	✓	✓	✓
84.	L1, L2, L3 Reactive Power	✓	✗	✗
85.	System Apparent Power	✓	✓	✓
86.	L1, L2, L3 Apparent Power	✓	✗	✗
87.	System Power Factor	✓	✓	✓
88.	L1, L2, L3 Power Factor	✓	✗	✗
89.	System Phase Angle	✓	✓	✓
90.	L1, L2, L3 Phase Angle	✓	✗	✗
91.	System Voltage THD	✓	✓	✓
92.	L1, L2, L3 Voltage THD	✓	✗	✗
93.	System Current THD	✓	✓	✓
94.	L1, L2, L3 Current THD	✓	✗	✗

# Energy Meter

## ZAM DN4U

### Order Code :

#### Ordering Information :

Product Code :

ED43 - M - 0 - 01 - 02 - B - 0 - B - 00ZG

**ZAM DN4U 3Ph Direct Connected Energy Meter**

**Current Range:**

02 - 0.25-5 A (100 A)

**Communication, Pulse Output and Digital Input:**

A : 2 SO Output and 2 Digital Input (ZAM DN4U-4T)

B : Modbus with 2 SO Output and 2 Digital Input (ZAM DN4U-MD)

Order Code Example : **ED43-M00102B0B00ZG**

**ZAM DN4U-MD** 3 Phase Direct Connected Energy Meter with Input voltage 100-289VLN, 0.25-5 A (100 A), Modbus with 2 SO Output and 2 Digital Input.

# Ziegler

Redefine Innovative Metering

**Ziegler Instrumentation UK Ltd.**

Central Buildings, Woodland close old woods Trading Estate, Torquay Devon, TQ2 7BB, United Kingdom  
+44-1376 335271 | [info@ziegler-instrument.com](mailto:info@ziegler-instrument.com) | [ziegler-instrument.com](http://ziegler-instrument.com)